



APPROACH^{SE}
Alu-Tech Bodyshell

www.baileyapproach.co.uk



CHOOSE A NEW DIRECTION

Bailey Motorhomes

CHOOSE A NEW DIRECTION... APPROACH^{SE}
Alu-Tech Bodyshell
the new Bailey motorhome range



Bailey Caravans have been developed using over sixty years of experience in caravan design and are manufactured in a state-of-the-art production facility to provide the very best in touring home quality and value. The company will now look to bring this same level of expertise to the Motorhome market with the introduction of the new Approach SE range.



Bailey motorhomes are coach-built using the same high performance Alu-Tech construction system used in our existing touring caravan ranges.

The result of one of the most comprehensive product design programmes the industry has ever known, the Alu-Tech construction system is seen by many as one of the most significant developments in leisure vehicle production technology for over thirty years.

Over the past twelve months Bailey has been working on modifying the Alu-Tech system using the latest 3-D modelling computer software to specifically suit the needs of a motorhome. The resulting vehicles have then been subjected to a series of accelerated life and structural tests as well as being given a thorough examination in a climate control chamber at the internationally renowned Millbrook Proving Ground to ensure that every aspect of the new designs have been thoroughly evaluated.



The result is a vehicle that is a triumph of engineering and technological advancement that offers real advantages of ownership in terms of performance and longevity. Most notably these include:-

GRADE III THERMAL CLASSIFICATION

Thicker body shell panels featuring superior grade polystyrene, plus additional localised insulation in traditional cold spot areas have greatly enhanced the thermal properties of the motorhome. As a result all motorhomes built using the Alu-Tech construction system have achieved the Grade III Classification of Thermal Insulation for EN1646-I*, keeping you warm in winter and cool in summer, as well as making your vehicle more economical to own.



BODY SHELL INTEGRITY

Engineered to ensure it remains weatherproof and structurally sound, the Alu-Tech body shell sets new standards in durability. Starting with an interlocking aluminium framework that cuts the number of external joints and fixing points by 90%, every conceivable effort has been made to reduce the number of potential water access

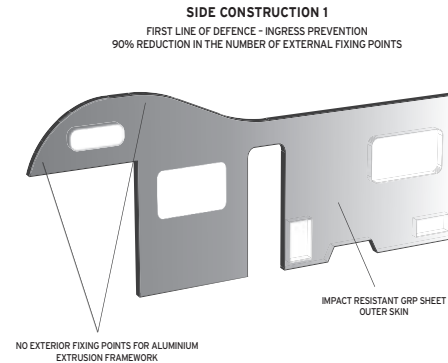

SIDE CONSTRUCTION 2
SECOND LINE OF DEFENCE - INGRESS MANAGEMENT

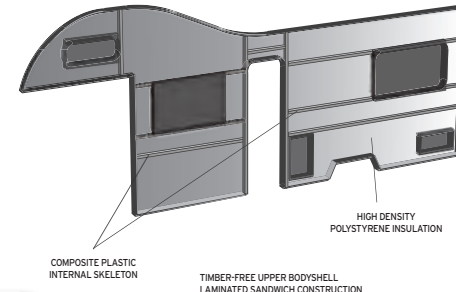

SIDE CONSTRUCTION 3
SECOND LINE OF DEFENCE - INGRESS MANAGEMENT

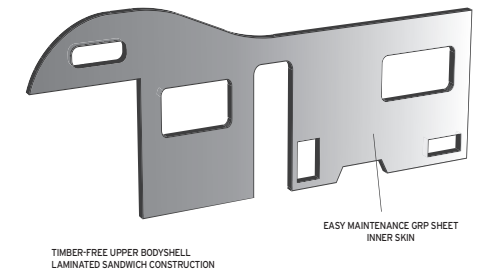

points and thus improve the overall integrity of the protective shell. While timber free body shell panels featuring a composite plastic internal skeleton offers a second line of defence, limiting the impact any possible ingress may cause.

The bodysell assembly, including the interface sections between cab and habitation area, consists solely of fully laminated panels cloaked in a GRP outer skin enhancing both the strength, durability and rigidity of the structure.

So confident are we of the performance of this new shell that it includes a comprehensive manufacturer's warranty and an **extended bodysell integrity guarantee**** providing you with additional peace of mind by protecting your investment.

For more information on the Alu-Tech construction system please visit www.baileyalu-tech.co.uk

**Classification verified in cold chamber testing at the Millbrook Proving Ground (August 2011)*

***Terms and conditions apply. Supplied with a 6 year bodysell integrity guarantee and a 3 year manufacturers components warranty. 4 Year extension to bodysell integrity guarantee available as a cost option (making 10 years in total). Please visit www.baileyapproach.co.uk for more information on the Approach SE warranty package.*

EIGHT/NINE PART FULLY BONDED EXTERIOR PANEL ASSEMBLY SYSTEM

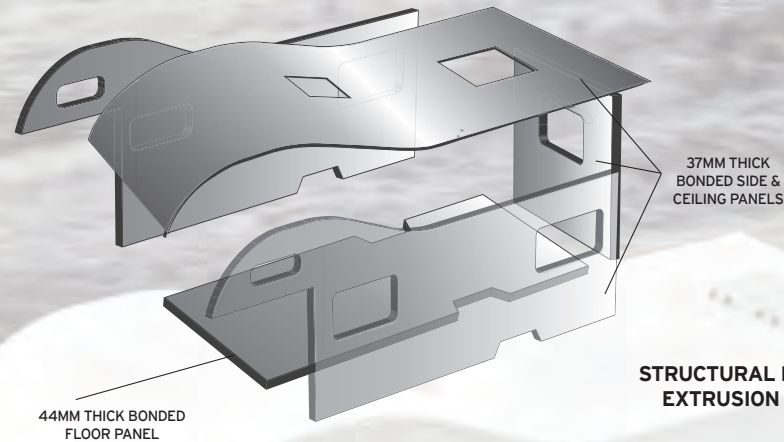

STRUCTURAL INTERLOCKING ALUMINIUM EXTRUSION EXTERNAL FRAMEWORK

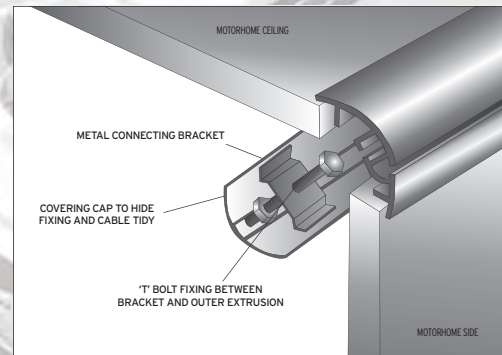

- STRUCTURAL FRAMEWORK
- NO EXTERNAL FIXING POINTS
- ENHANCED RIGIDITY

Approach SE - *Designed to be driven*

Designed to be driven, Approach SE is powered by the Peugeot 2.2 Hdi 130 bhp engine complete with a 6-speed manual gearbox. All models will be built on the new Euro 5 base and will thus benefit from the resulting improvements in performance and reduction in vehicle emissions. This is complemented by the luxury lightweight AL-KO AMC chassis which, with its lower centre of gravity, provides a more balanced weight distribution that improves road holding and braking efficiency as well as allowing increases in user payloads.

Driver and passenger comfort whilst en-route is catered for with a pair of fully adjustable front swivel seats with twin arm rests, cab air conditioning and engine cruise control all included as standard.



Fully adjustable front swivel seats with twin arm rests

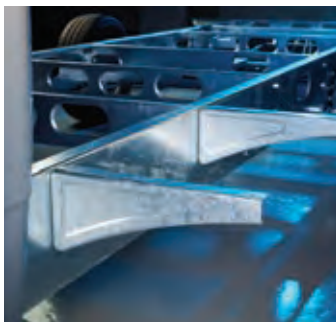

AL-KO AMC Chassis



Peugeot 2.2 Hdi 130 bhp engine



6-speed manual gearbox



Cab air conditioning

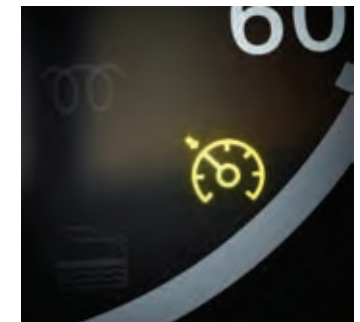

Cruise control

Safety considerations remain of paramount importance and thought has been given to this aspect of the design throughout the vehicle with dual air bags fitted in the front cab of all models and additional strengthening to the floor and furniture made in the dedicated rear passenger areas to enhance the effectiveness of the four fitted three point seat belts (Approach SE 745 & 760 only).

Built with practicality in mind models come supplied with a 105Ah auxiliary battery to give greater independence away from a mains power source and a 100 litre fully insulated external fresh water tank for continuous supply in cold temperature conditions. The dual fuel Truma 'Combi' central heating system provides effective heating en-route or on site and combines with the superior performance of the Alu-Tech bodyshell to make the Approach SE a genuine four-season vehicle.



105Ah auxiliary battery



Dual fuel Truma combi boiler with en-route operation



Driver and passenger airbags



Additional strengthening to furniture in dedicated rear passenger area (745 & 760 only)



Four Three point seatbelts fitted as standard in dedicated rear passenger area (745 & 760 only)

Approach SE - *Light and spacious inside*

Once at your chosen destination the Approach SE provides you with a light and spacious habitation area, with an internal headroom of 1.96m and an internal body width of 2.27m, which are beautifully showcased by large PolyClassic windows, complete with pleated cassette blinds, and clear canopy Heki rooflights throughout. This space is then expertly managed to ensure storage capacity and accessibility is optimised in all areas of the motorhome making Approach SE as practical as it is comfortable.



Approach SE 760 Rear lounge



Approach SE 745 Side dinette with 2 dedicated rear passenger seats



Lift up front bed boxes provide easy access to ground level storage (model specific)



Horrex pleated flyscreens and sunblinds



Taking design cues from our most popular caravan ranges, interiors feature Italian styled furniture in a rich 'walnut' wood veneer which combines with the luxurious Vivaldi soft furnishings, constructed using premium quality Belgian fabrics and fully sprung cushions, to make the habitation area both warm and inviting.

As people have come to expect from Bailey, models are extremely well specified and are packed with the home comforts owners will need for a relaxing and enjoyable holiday. Notably these include fully equipped kitchens featuring large capacity Dometic 8-Series refrigerators, a new Thetford 'anti-rattle' oven, a stainless steel 700 watt microwave and cleverly designed washrooms all of which feature fully lined separate shower cubicles.



Approach SE 620 Washroom















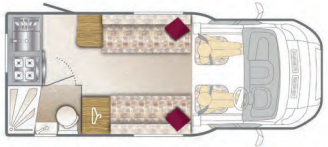

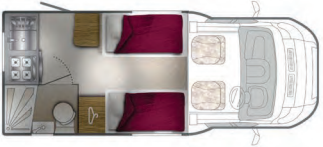

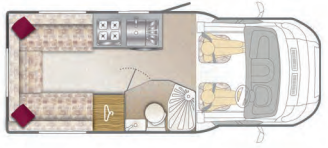
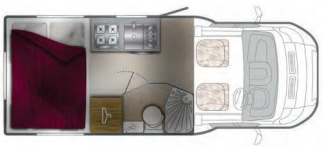

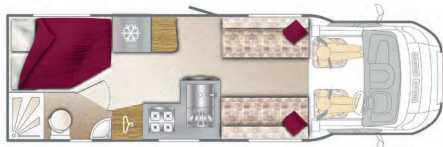
Approach SE 760 Over cab bed (Bed linen available as a cost option)

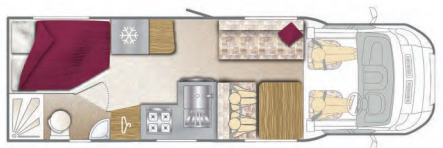

Approach SE 760 Kitchen

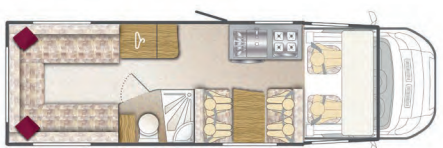

Approach SE 740 (Bed linen available as a cost option)

	<p>APPROACH SE 620 </p> <p>• </p>	<p>☾ </p>	<p>☾ </p>
	<p>APPROACH SE 625 </p> <p>• </p>	<p>☾ </p>	
	<p>APPROACH SE 740 </p> <p>• </p>	<p>☾ </p>	
	<p>APPROACH SE 745 </p> <p>• </p>	<p>☾ </p>	
	<p>APPROACH SE 760 </p> <p>• </p>	<p>☾ </p>	<p>☾ </p>

Technical Information	620	625	740	745	760
Peugeot Engine	130bhp	130bhp	130bhp	130bhp	130bhp
Engine Capacity	2198cc	2198cc	2198cc	2198cc	2198cc
Engine Power	130bhp @ 3500rpm	130bhp @ 3500rpm	130bhp @ 3500rpm	130bhp @ 3500rpm	130bhp @ 3500rpm
Engine Torque	320Nm @ 2000rpm	320Nm @ 2000rpm	320Nm @ 2000rpm	320Nm @ 2000rpm	320Nm @ 2000rpm
Roof Profile	Low Profile	Low Profile	Low Profile	Low Profile	High Line
Chassis	AL-KO AMC	AL-KO AMC	AL-KO AMC	AL-KO AMC	AL-KO AMC
Thermal Insulation Grade	3	3	3	3	3
Designated Travelling Seats	2	2	2	4	6
Berths	2	2	4	4	6
Overall Length	5.966m/19'7"	6.611m / 21'8"	7.519m/24'8"	7.519m/24'8"	7.519m/24'8"
Overall Body Width (Inc marker lights & exc mirrors)	2.420m/7'11"	2.420m/7'11"	2.420m/7'11"	2.420m/7'11"	2.420m/7'11"
Overall Height	2.638m/8'8"	2.638m/8'8"	2.638m/8'8"	2.638m/8'8"	2.99m/9'10"
Tyre Size	215/70 R15 LI109Q	215/70 R15 LI109Q	215/70 R15 LI109Q	215/70 R15 LI109Q	215/70 R15 LI109Q
MTPLM	3500kg/68.9cwt	3500kg/68.9cwt	3500kg/68.9cwt	3500kg/68.9cwt	3850kg/75.8cwt
MRO	2782kg/54.8cwt	2939kg/57.9cwt	2990kg/58.9cwt	3051kg 60.1cwt	3182kg/62.6cwt
Total User Payload	718kg/14.1cwt	561kg/11.0cwt	510kg/10.0cwt	449kg 8.8cwt	668kg/13.1cwt
Maximum Recommended Trailer Weight	2000kg	2000kg	2000kg	2000kg	1650kg
Gross Train Weight	5500kg	5500kg	5500kg	5500kg	5500kg
Fresh Water Tank	100 litre	100 litre	100 litre	100 litre	100 litre
Waste Water Tank	100 litre	100 litre	100 litre	100 litre	100 litre
Gas Locker Capacity	1 x 10kg & 1 x 6kg	1 x 10kg & 1 x 6kg	1 x 10kg & 1 x 6kg	1 x 10kg & 1 x 6kg	1 x 10kg & 1 x 6kg

Bed Sizes	620	625
Front Double	2.236m x 1.538m (7'4" x 5'0")	-
Front N/S Single	2.101m x 0.730m (6'11" x 2'4")	-
Front O/S Single	1.925m x 0.730m (6'3" x 2'4")	-
Rear Double	-	2.236m x 1.832m (7'4" x 6'0")
Rear N/S Single	-	1.832m x 0.730m (6'0" x 2'4")
Rear O/S Single	-	1.832m x 0.730m (6'0" x 2'4")
Overcab Bed	-	-

Bed Sizes	740	745
Front Double	2.236m x 1.329m (7'4" x 4'4")	2.236m x 1.329m (7'4" x 4'4")
Front N/S Single	-	-
Front O/S Single	-	-
Rear Double	1.935m x 1.370m (6'4" x 4'6")	1.935m x 1.370m (6'4" x 4'6")
Rear N/S Single	-	-
Rear O/S Single	-	-
Overcab Bed	-	-

Bed Sizes	760
Front Double	1.838m x 1.095m (6'0" x 3'7")
Front N/S Single	-
Front O/S Single	-
Rear Double	2.236m x 1.832m (7'4" x 6'0")
Rear N/S Single	1.832m x 0.730m (6'0" x 2'4")
Rear O/S Single	1.832m x 0.730m (6'0" x 2'4")
Overcab Bed	2.150m x 1.270m (7'0" x 4'2")





Vivaldi upholstery

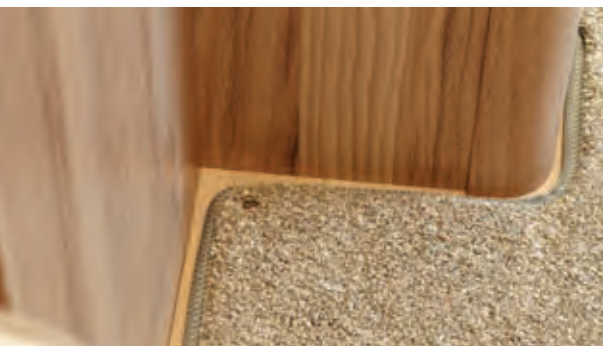

Drop in carpets



Stainless steel 700 watt microwave

VEHICLE CONSTRUCTION

Peugeot Boxer Cab

Peugeot 3 Year/100,000 mile warranty • Peugeot Assist Cover for 12 months • Metallic silver cab with colour coded bumpers • Remote central locking for cab and habitation door • Electric windows • Remis concertina windscreen and side window blinds • Electric heated wing mirrors with direction indicators • Peugeot 2.2 Hdi (High Pressure Direct Injection Engine) 130 BHP • Six speed manual gear box • Variable power steering • Anti-lock braking system (ABS) • Electronic Brake Force Distribution (EBFD) • Emergency Brake Assist (EBA) • Engine immobiliser • Cruise control • Cab air conditioning • Driver and passenger airbags • Fully adjustable upholstered driver and passenger seats with twin armrests • Removable cab carpet • Radio & CD Player (MP3 compatible) and 2 door speakers.

AL-KO AMC Chassis

Wide axle AL-KO AMC Chassis • Premium Michelin branded tyres • Mudflaps • AL-KO Chassis mounted spare wheel carrier and spare wheel • Chassis prepared for towbar.

Alu-Tech Bodyshell

Supplied with a 6 year bodyshell integrity guarantee and a 3 year manufacturers components warranty. 4 Year extension to bodyshell integrity guarantee available as a cost option (making 10 years in total)* • Fully insulated shell to Grade III classification of EN1646-1 • European Whole Vehicle Type Approval.

Construction

Structural interlocking aluminium extrusion external framework with no external fixing points and an integral water management system • Eight or Nine part fully bonded exterior panel assembly system featuring • Panel thicknesses of: Sides 37mm, Ceiling 37mm & Floor 44mm • Upper body panels manufactured using superior bead application laminating technology for a stronger more consistent bond • Upper body panels built using a timber free construction, incorporating a composite plastic internal skeleton, a high density polystyrene insulation and a GRP inner wall lining • Upper body panels incorporating low absorbency buffer zones surrounding window

and door apertures • Upper body panels cloaked in a single sheet impact resistant GRP • Underfloor GRP protection.

Habitation Area

Supplied with a 3-Year manufacturer's warranty* • European Whole Vehicle Type Approval.

EXTERIOR FEATURES

Polyplastic double glazed windows throughout with night latch ventilation • High line overcab windows (model specific) • Hartal habitation door with window, blind & bin • Habitation door step well with non-slip mat & grab handle • Flush fit integral exterior service doors • Exterior storage and underfloor storage lockers (model specific) • LED awning light with integral water management system • Flush fitting high level brake light • Fixing points for rear mounted cycle rack • Fixing points for exterior ladder and roof rack.

INTERIOR FEATURES

Space

Internal headroom of 1.96m (6'5") • Internal body width of 2.27m (7'5")

Furniture & Soft Furnishings

Bailey 'Walnut' furniture finish • Free standing table with dedicated storage • Side dinette table with dedicated storage (model specific) • Slide out bed boxes for easy bed make up (model specific) • Pull out roller slats for easy bed make up (model specific) • Aircraft style overhead locker system with split level storage, domestic style metal hinges and positive door catches • Structural locker dividers with greater load bearing capacity • Italian design overhead locker doors • Contrasting kitchen overhead locker system • Standard 'Vivaldi' soft furnishings with co-ordinating curtains and two scatter cushions • Fully sprung upholstery featuring premium quality fabrics, high density filling and superior cushion construction and a De-Luxe sprung double bed mattress (model specific) • Gas strut assisted fixed bed operation (model specific) • Split section loose fit drop in carpets (50 oz pile density) • Premium quality fixtures and fittings in chrome finish.

SERVICES:

Electrical System

Digital control panel with touchscreen controls located over doorway • 105 ampere / hour battery • 12v internal lighting throughout • 230v power supply with up to five interior sockets • Up to two TV stations with 230v/12v/aerial sockets • Domestic style consumer unit with dedicated access door • Switch mode battery charger with 20 amps output • RCD/MCD protection for mains electric system • 25 metre mains connecting lead • Pre-Wired for satellite and aerial connection and rear view camera.

Water & Gas System

Dual fuel Truma Combi Boiler with en-route on-site operation (4kw gas & 2kw electric) • Dedicated gas locker compartment • Propane/Butane gas 30mb regulator mounted in gas locker compartment • Whale Aqua smart II on-board water pump with Aquasource layflat filling pipe • 100 litre external insulated fresh water tank with baffles and level sensor • Fresh water tank heater for winter protection and overflow • 100 litre external waste water tank with baffles and level sensor • Inboard pressurised hot and cold fresh water system with self priming pump • Rigid pipe waste plumbing system • Swivel Thetford C260 cassette toilet with integrated header tank • Inboard shower unit with ceramic ball mixer tap and Ecocamel shower head • Fully lined separate shower cubicle with bi-fold partition door • 'Belfast' style washroom sink with ceramic ball mixer tap (model specific).

Kitchen Equipment

Dometic 115 litre refrigerator with electronic ignition and detachable full width freezer compartment (capacity increases to 122 litres when freezer compartment is removed) (model specific) • Dometic 117 litre refrigerator with electronic ignition and detachable full width freezer compartment (capacity increases to 145 litres when freezer compartment is removed) (model specific) • Thetford recessed 4-burner hob incorporating flush fitting glass hinged lid, conveniently located controls and rear splash back • Thetford combined grill and domestic style glass fronted 'anti-rattle' oven with electronic ignition and flame failure device • Stainless steel 700 watt microwave oven conveniently located at eye level • Thetford large capacity recessed sink with removable draining board, chopping board and ceramic ball mixer tap.

GENERAL EQUIPMENT

Lap and diagonal belts on all designated travelling seats (model specific) • Horrex pleated flyscreen and sunblinds to all windows • Horrex pleated full length flyscreen to habitation door • Midi Heki roof light located over lounge and/or bedroom (model specific) • Mini Heki roof light located over kitchen (model specific) • Branded dual cone stereo speakers for superior sound quality • Carbon monoxide and smoke alarms.

**Terms and conditions apply. Please visit www.baileyapproach.co.uk for more information on the Approach SE warranty package.*



Dometic 115 litre fridge (model specific)



Thetford 'anti-rattle' oven



Dedicated table storage



Belfast style washroom sink (model specific)



Fully lined separate shower cubicle



Dedicated washroom storage



www.baileyapproach.co.uk

South Liberty Lane, Bristol BS3 2SS, England



80% Recycled paper



MIX Paper FSC® C002239

This brochure does not constitute an offer by Bailey Caravans Ltd (Bailey). Bailey reserves the right to alter specifications and prices as market and supply conditions demand. Your Bailey retailer will confirm all specification details prior to you making your purchasing decision. E. & O. E. Bailey retailers sell our products of their own choice and not as agents of Bailey. Accordingly they have no authority to bind Bailey or to make any representation or undertaking whatsoever on behalf of Bailey. All household items illustrated in this brochure are used to enhance photography and are for display purposes only. They are not supplied with your motorhome. Photographic colour reproduction is subject to the limitations of the production process.

Design & Print: Kingsdown Photography: Alan Bond Issued: August 2012